

## **PROTEKT® PROSCAN FACIAL RECOGNITION & TEMPERATURE SCANNER**

The Propekt® ProScan Facial Recognition and Temperature Scanner offers a non-contact method to detect temperature irregularities within a few seconds. When utilized as the first of a two-point check system where an elevated temperature (fever) is then confirmed by a second FDA approved medical thermometer such as the Propekt® ProTemp Infrared Thermometer this unit is fully FDA compliant. This is a great non-invasive way to help prevent and control the spread of infectious diseases.



### **Features:**

- 8-inch IPS full-view LCD display.
- Industrial-class appearance, water resistant and dustproof design makes the unit stable and reliable.
- Supports a 30,000 face database. The 1:1 comparison recognition rate is more than 99.7%, accurate.
- Supports accurate face recognition and comparison even while wearing a mask.
- Uses an industrial-grade binocular wide dynamic camera, night infrared and LED dual photo flood lamp ensuring accurate readings in all lighting conditions.
- Supports human body temperature detection and temperature display up to distances of 3 feet with a temperature accuracy of 99.8%.
- Temperature detection in only a few seconds.
- Supports automatic alarm for body temperature abnormality with customizable thresholds.
- Can be used with access gates interface allowing or denying access based on temperature scan.
- Multiple mounting possibilities
  - Desktop base
  - Floor standing base
  - Attached to an access gate
- Utilizes temperature measuring module technology designed in Belgium.

**Give us a call for more information!**

**732-845-5288**

## Appearance and Size:



## Multiple Interface Options:

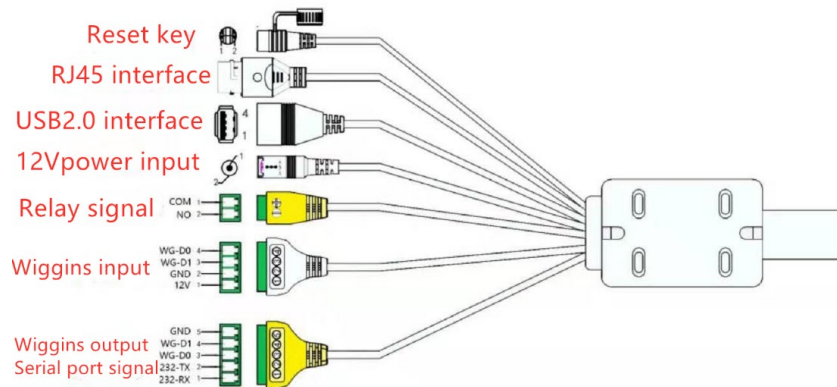

**Give us a call for more information!**

**732-845-5288**

## **Protekt® ProTemp Infrared Non-Contact Thermometer**



Temperature taking has never been easier with the Non-Contact Thermometer. The Protekt ProTemp provides convenience, accuracy and precision when taking a temperature. With the push of a button, instantly and accurately take a person's temperature without the need of any physical contact. Simply point the thermometer at the patient's forehead, click "Scan" and their temperature instantly will be displayed.

- Non-touch eliminates cross contamination
- Hygienic and easy to use
- High temperature alert
- Fast and accurate, 1 second response time
- FDA & CE approved
- Data can be displayed in either Celsius or Fahrenheit.
- Body-Mode Temperature Range:  
89.6°F ~ 109.2°F (32°C ~ 42.9°C)
- Measuring Distance: 1.2in ~ 2in (3cm ~ 5cm)
- Accuracy:  $\pm 0.6^{\circ}\text{F}$  ( $0.3^{\circ}\text{C}$ )
- Automatic shut off.
- Practical and easy to use.
- 6 Month limited warranty.

### **Features and Benefits:**

- Designed to take the body temperature of a person without the interference from the heat of the surrounding environment.
- Never wake the patient to take their temperature.
- Audible alarm when the temperature is too high. [ $\leq 100.4^{\circ}\text{F}$  ( $38^{\circ}\text{C}$ )]
- Memory for 32 previous measurements.
- Back-lit LCD screen.
- Works with 2 AA batteries (batteries included)

**Give us a call for more information!**

**732-845-5288**